

Submersible waste water pumps
Discharge BSP 3" / DN 80.
Vortex impeller, spherical clearance 50 – 65 mm.

TP 53 V

Application

HOMA TP 53 series pumps are suitable for pumping drainage water or waste water. With 50 and 65 mm spherical clearance they are able to pump liquids with larger suspended solids like fibres, textiles etc. They are used for various applications in public and private sector, trade and industry. **DIN EN 12050-2:** Conformity and design approved and controlled by LGA.

Installation: Transportable or permanent. Models with float switch control for automatic pump operation, depending on liquid level in the sump.

Pumped liquid: Clear water and drainage water, sewage containing soft solids. Max. liquid temperature: 40°C short term up to 60°C.

Operation: Permanent (S1).

Design

Fully submersible, compact integrated motor-pump unit consisting of:

Pump: Single stage centrifugal pump with horizontal discharge BSP 3" M

Impeller: V = Vortex impeller for liquids containing a high level of impurities or fibrous matter and containing gas. Spherical: clearance 50 up to 65 mm.

Motor: Fully submersible, pressure tight electric motor. Insulation class H. Degree of protection IP 68. Thermal sensors embedded in the winding

on request (standard with TP53V50, TP53V17/2W and model Ex).

Motor Start:

TP53V13-14: Direct-on-line

TP53V50: Direct-on-line or Star-delta-start

Cable:

TP53V13-40: H07RN-F 4 G 1,5

TP53V13-40Ex: H07PLUS 6 G 1,5

TP53V50(Ex): H07RN-F(PLUS) 10 G 1,5

Shaft/Bearing: Large diameter stainless steel rotor shaft, pre-lubricated bearings.

Seals: Combination of mechanical seals (silicon-carbide/silicon-carbide) in a separate oil chamber. Models up to 1,6 kW/2-pole with mechanical seal and lip seal. Oil inspection from outside.

Explosion protection: All models available with explosion proof motors according to

Ⓜ II 2 G Ex c d II B T4(T3).

Performance

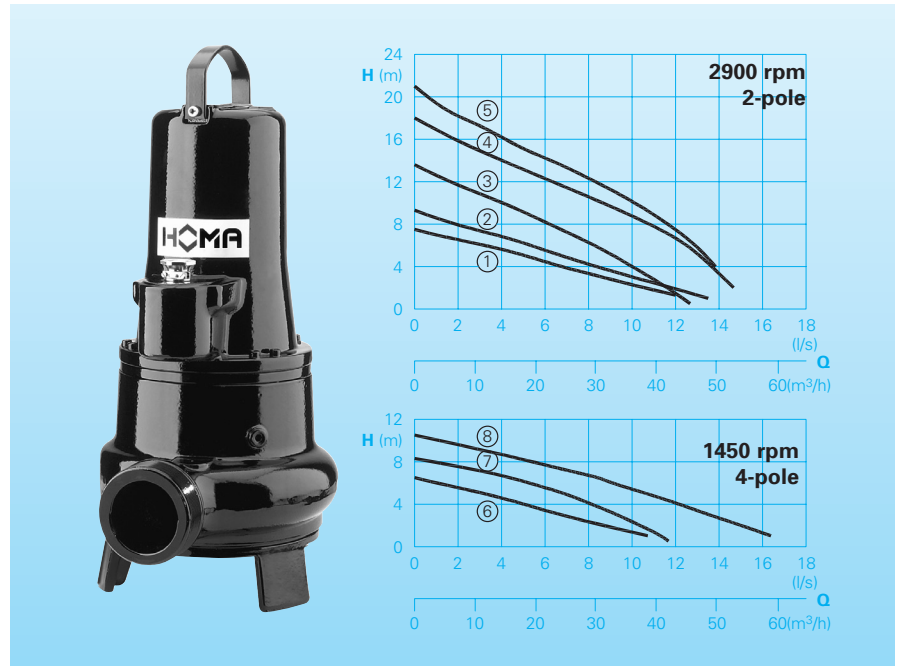

Technical Data

Curve No.	Pump typ	Motor P ₁ (kW)	P ₂ (kW)	Capacitor* (µF)	Speed (rpm)	Nom. current (A)	Spherical clearance (mm)	Weight (kg)
①	TP 53V 17/2 W (A) (Ex)	1,6	1,2	30	2900	7,6	65	27,0**
②	TP 53V 17/2 D (A) (Ex)	1,6	1,2		2900	2,9	65	27,0**
③	TP 53V 26/2 D (A) (Ex)	2,6	2,1		2900	4,5	50	40,0
④	TP 53V 40/2 D (A) (Ex)	4,0	3,4		2900	6,6	50	45,0
⑤	TP 53V 50/2 DT (Ex)	5,2	4,4		2840	8,7	50	56,0
⑥	TP 53V 11/4 W (A)	1,2	0,9	40	1450	5,8	62	40,0
⑥	TP 53V 11/4 D (A) (Ex)	1,1	0,8		1450	2,4	62	40,0
⑦	TP 53V 13/4 D (A) (Ex)	1,3	1,0		1450	2,6	50	40,0
⑧	TP 53V 23/4 D (A) (Ex)	2,3	1,8		1450	5,0	62	45,0

Model W: 230-240V/1Ph 50Hz

Model D: 400-415V/3Ph 50Hz

Model A: With automatic level control HOMA-Nivomatik

* **Kondensator:** For the operation it is necessary to install a capacitor in the control box.

Model Ex: Explosion proof

** **Weight Ex Model:** + 5 kg

Materials

Motor housing, Impeller, Pump housing	Cast iron EN-GJL-250
Rotor shaft, screws	stainless steel
Mechanical seal	Siliziumkarbid
Seal kit	NBR

Equipment supplied

Pumps with base stand, without auto-coupling (see accessories):

Model W (230 V / 1 Ph):

10 m of cable. Control box W19; WT19 (Standardpump); WT19 (Ex-Pump) available as accessories.

Model D (400 V / 3Ph):

10 m of cable. Control box D32; DT32 available as accessories.

Model A: With additional automatic level control and control box DA10/32; DA10/12 with overload protection, manual-auto switch and 10-m of cable. 1Ph- model with integrated capacitor. Model Ex with intrinsically safe relay.

Dimensions and Installation (all dimensions in mm)

Free standing pump with base stand

TP53V17/2W+D(Ex)

TP53V11/4W(D)(Ex)
TP53V23/4D(Ex)

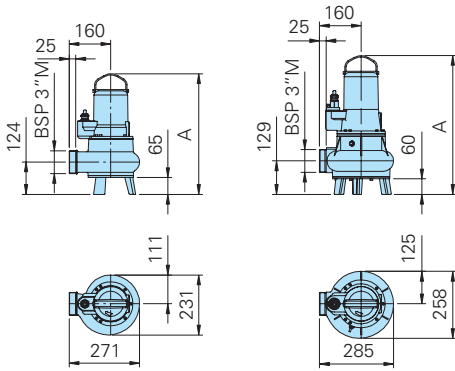

TP53V40/2D(Ex)
TP53V26/2D(Ex)
TP53V13/4D(Ex)

TP53V50/2DT(DEx)

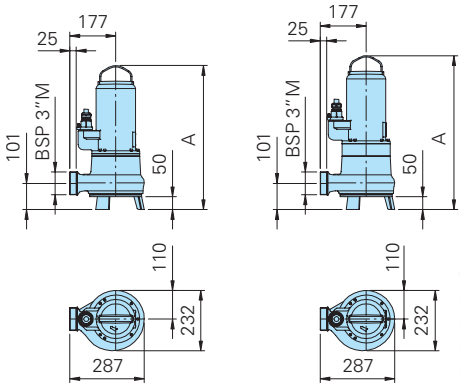

Permanent sump installation with auto-coupling system.

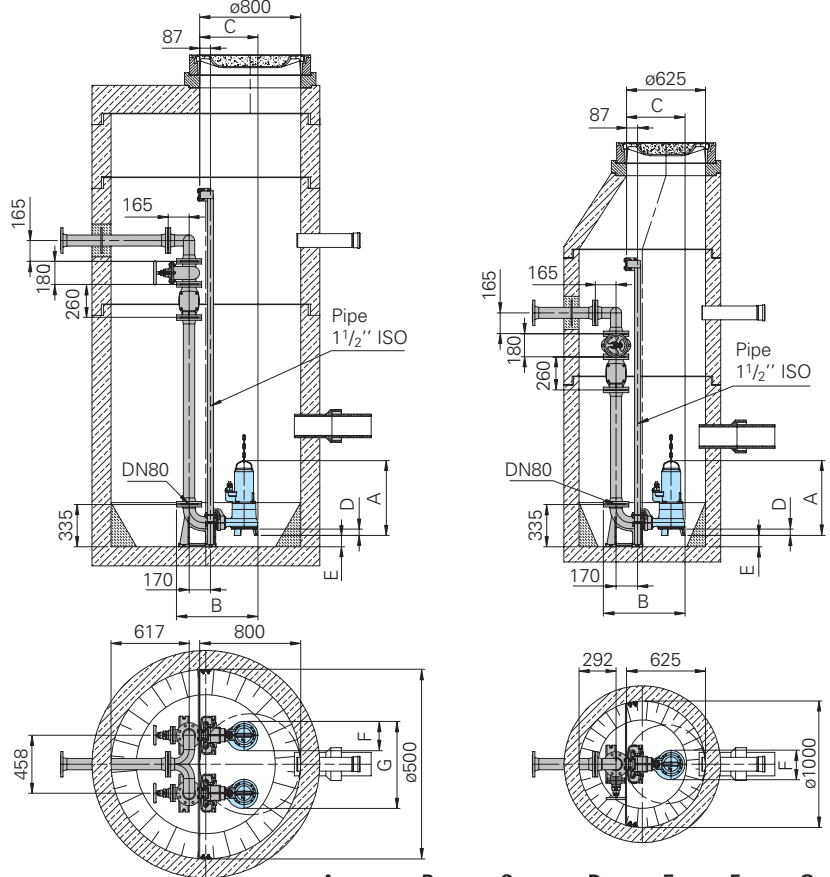

Type	A	B	C	D	E	F	G
TP53V50/2DT(DEx)	593	645	462	50	89	232	690
TP53V40/2D(Ex)	555	645	462	50	89	232	690
TP53V13/4D(Ex), TP53V26/2D(Ex)	518	645	462	50	89	232	690
TP53V17/2W + D(Ex)	465 (472)	629	446	65	66	231	689
TP53V11/4W+D(Ex)	535	648	465	60	61	258	716
TP53V23/4D(Ex)	572	648	465	60	61	258	716

Accessories

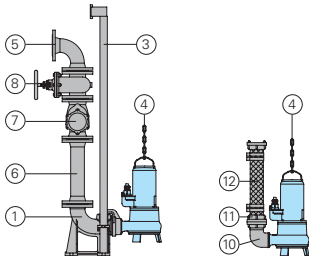

Description	Dimension	Part No.
① Cast iron autocoupling system with auto-coupling with flange DN 80 and upper slide rail bracket BSP 1 1/2"		
- Typ KK80/R3"	BSP 3" F	8604035
- Typ KK80/80	DN 80	8604025
○ Auto-coupling system complete or partial in stainless steel	all types	on request
○ Screw-kits for installation of coupling system		on request
Threaded flange	DN 80/BSP3" F	2215080

Description	Dimension	Part No.
③ Guide rails, pair, per m steel galvanized	1 1/2" dia.	2190155
stainless steel	1 1/2" dia.	2190254
④ Lifting chain, proved capacity up 200 kg division 984 mm, 4x12 with eyelet 2m long		2800371
special lengths		on request
Shackle stainless steel for chain 5 mm Ø		2801390
⑤ 90° flanged elbow	DN 80	2153302
	DN 100	2153303
Flanged Y-piece for twin pump arrangement, horizontal discharge	3x DN 80	2160006
	DN 80/80/100	2160008
	3x DN 100	2160010
(vertical discharge on request)		
⑥ Flanged discharge pipe with gasket and fixing bolts, 1 m long	DN 80	2152081
	DN 100	2152201
Discharge pipe, per additional m	DN 80	2150080
	DN 100	2150100
Flanged reducer		on request
⑦ Check valve with flanges	DN 80	2212807
	DN 100	2212809

Description	Dimension	Part No.
⑧ Wedge gate valves with flanges	DN 80	2216080
	DN 100	2216100
⑩ 90° elbow		
Flanged 90° elbow	BSP3" F/M	2111805
	DN 80	2153302
Threaded flange	DN 80/BSP3" F	2215080
⑪ STORZ-fixed coupling	B-3" F	2010602
STORZ-hose coupling	B-75 mm Ø	2013502
⑫ Reinforced hose with 2 B-size half couplings, 75 mm dia.	2 m lang	2161042
	3 m lang	2161043
	5 m lang	2161045
Flanged reinforced hose 90 mm dia., DN 80	2 m lang	2161032
	3 m lang	2161033
	5 m lang	2161035
Reinforced hose per m	Ø 75 mm	2632075
	Ø 90 mm	2632090
Flanged spigot DN 80	90 mm Ø	2171014
Hose band	85/20	2308520
	92/20	2309221
○ Control panel for single or twin pump stations for automatic operation		on request



HOMA Pumpenfabrik GmbH
P.O.Box 22 63, D-53814 Neunk.-Seelscheid
Tel. +49 (0) 22 47/702-0, Fax +49 (0) 22 47/702-44
e-mail: info@homa-pumpen.de
www.homapumps.com