

## Electric submersible pumps for waste water containing solids. Single channel impeller, spherical clearance 50 mm.

### TP 50 M

#### Application

Homa TP 50 series pumps are suitable for pumping drainage water or waste water. With 50 mm spherical clearance they are able to pump liquids with larger suspended solids like fibres, textiles etc. They are used for various applications in public and private sector, trade and industry.

**DIN EN 12050-2:** Conformity and design approved and controlled by LGA.

**Installation:** Transportable or permanent. Models with float switch control for automatic pump operation, depending on liquid level in the sump.

**Pumped liquid:** Clear water and drainage water, sewage containing soft solids. Max. liquid temperature: 40°C short term up to 60°C.

**Operation:** Permanent (S1).

#### Design

Fully submersible, compact integrated motor-pump unit consisting of:

**Pump:** Single stage centrifugal pump with horizontal discharge BSP 2 1/2" M.

**Impeller:** Closed single channel impeller for liquids containing impurities and sludge with solid particles. Spherical clearance 50 mm.

**Motor:** Fully submersible, pressure tight electric motor. Insulation class H. Degree of protection IP 68. Thermal sensors embedded in the winding on request (standard with TP50M50, TP50M12/2W, TP50M17W and model Ex).

Motor start: TP50M12-37: Direct-on-line  
TP50M50: Direct-on-line or Star-delta-start  
Cable:

TP50M12-37: H07RN-F 4 G 1,5  
TP50M12-37Ex: H07PLUS 6 G 1,5

TP50M50(Ex): H07RN-F(PLUS) 10 G 1,5

**Shaft/Bearing:** Large diameter stainless steel rotor shaft, pre-lubricated bearings.

**Seals:** Combination of mechanical seals (silicon-carbide/silicon-carbide) in a separate oil chamber (models above 1,8 kW). Models up to 1,6 kW with mechanical seal and lip seal. Oil inspection from outside.

**Explosion protection:** All models available with explosion proof motors according to  II 2 G Ex c d II B T4(T3).

#### Performance

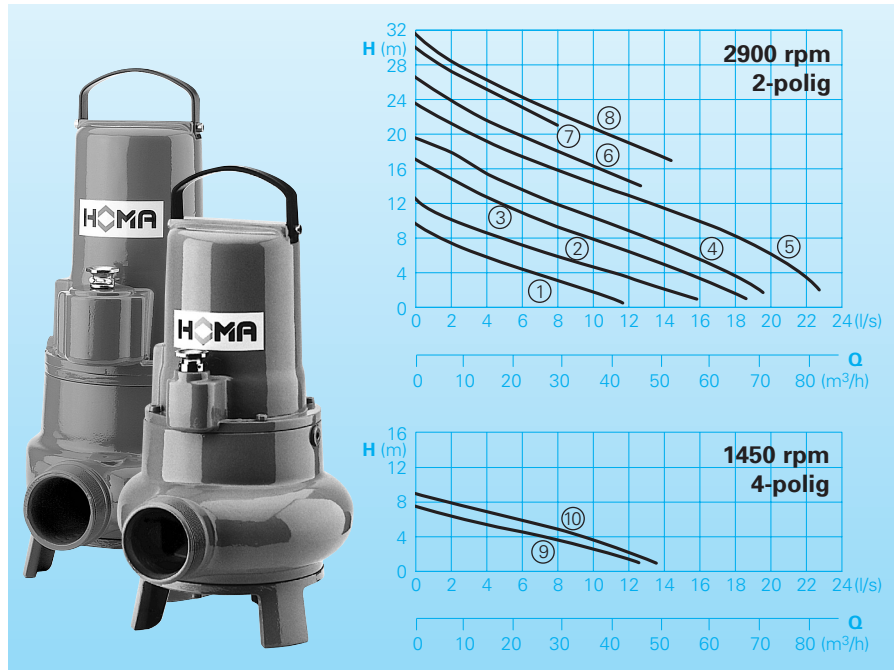

#### Technical Data

Curve No.	Pump type	Motor P <sub>1</sub> (kW)	P <sub>2</sub> (kW)	Capacitor* (µF)	Speed (rpm)	Nominal current (A)	Weight (kg)
①	TP 50M 12/2 W (A) (Ex)	1,1	0,8	25	2900	4,8	26,0**
②	TP 50M 17/2 W (A) (Ex)	1,6	1,2	30	2900	7,6	27,0**
①	TP 50M 11/2 D (A) (Ex)	1,0	0,8		2900	1,9	26,0**
②	TP 50M 14/2 D (A) (Ex)	1,3	1,0		2900	2,5	27,0**
③	TP 50M 23/2 D (A) (Ex)	2,3	1,8		2900	3,8	40,0
④	TP 50M 26/2 D (A) (Ex)	2,6	2,1		2900	4,5	40,0
⑤	TP 50M 37/2 D (A) (Ex)	3,7	3,1		2900	6,5	45,0
⑥	TP 50M 37/2 MD (A) (Ex)	4,0	3,4		2900	6,6	45,0
⑦	TP 50M 37/2 HD (A) (Ex)	3,7	3,1		2900	6,5	45,0
⑧	TP 50M 50/2 DT (Ex)	5,2	4,4		2840	8,7	56,0
⑨	TP 50M 12/4 W (A)	1,2	0,9	40	1450	5,8	40,0
⑩	TP 50M 13/4 D (A) (Ex)	1,3	1,0		1450	2,6	40,0

**Model W:** 230-240V/1Ph 50Hz

**Model D:** 400-415V/3Ph 50Hz

**Model A:** with automatic level control  
HOMA-Nivomatik

\* **Capacitor:** For the operation it is necessary to install a capacitor in the control box.

**Model Ex:** Explosions proof

\*\* **Weight Ex Model:** + 5 kg

#### Materials

Pump housing, impeller, motor housing	Cast iron EN-GJL-250
Rotor shaft, screws	stainless steel
Mechanical seal	Silicon-carbide
Wear ring	Bronze
Elastomere	NBR

#### Equipment supplied

Pumps with base stand, without auto-coupling (see accessories)

**Model W (230-240 V / 1 Ph):**

10 m of cable. Control box W19 (Standard-pump) WT19 (Ex-Model.) available as accessories.

**Model D (400-415 V / 3Ph):** 10 m of cable. Control box D32; DT32 available as accessories.

**Model A:** With additional automatic level control, control box DA10/32; DA10/12; WA10/19 with overload protection, manual-auto switch. Model WA with integrated capacitor. Model Ex with intrinsically safe relay.

**Dimensions and Installations** (all dimensions in mm)

**Free standing pump with base stand**

TP50M12/2W(Ex), TP50M17/2W(Ex) TP50M12/4W, TP50M13/4D(Ex) TP50M37/2MD(Ex), TP50M37/2(H)D(Ex)  
 TP50M11/2D(Ex), TP50M14/2D(Ex) TP50M23/2D(Ex), TP50M26/2D(Ex)

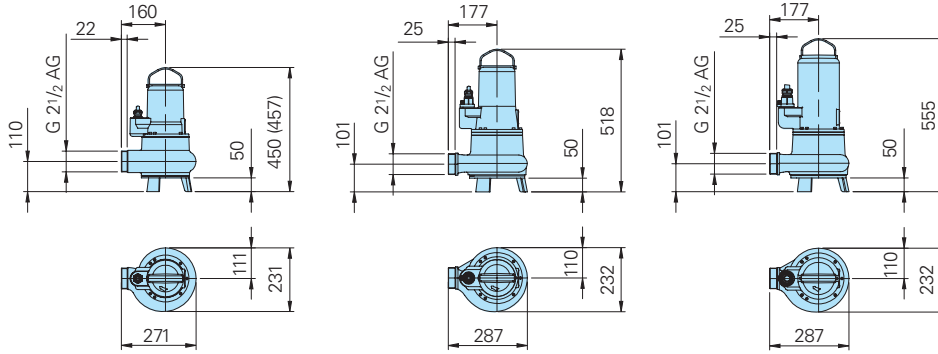

**TP50M50/2(DT)(Ex)**

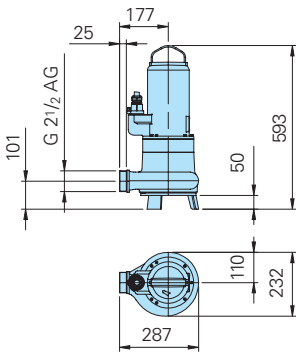

Typ	A	B	C	D	E	F	G
TP50M50/2D(TDEx)	593	575	412	50	39	232	612
TP50M37/2MD(Ex)+(H)D(Ex)	555	575	412	50	39	232	612
TP50M12/4W, TP50M13/4D(Ex), TP50M23-26/2D(Ex)	518	575	412	50	39	232	612
TP50M12-17/2W(Ex), TP50M11-14/2D(Ex)	450(457)	559	396	50	31	231	611

**Permanent sump installation with auto-coupling syste**

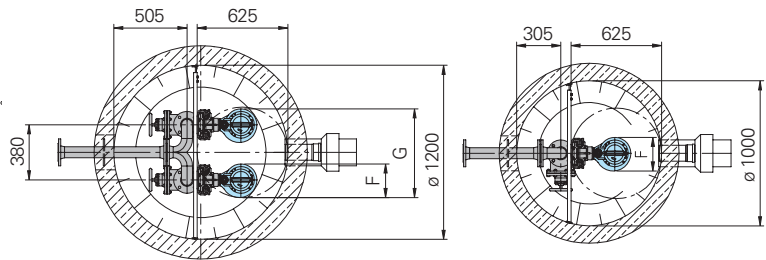
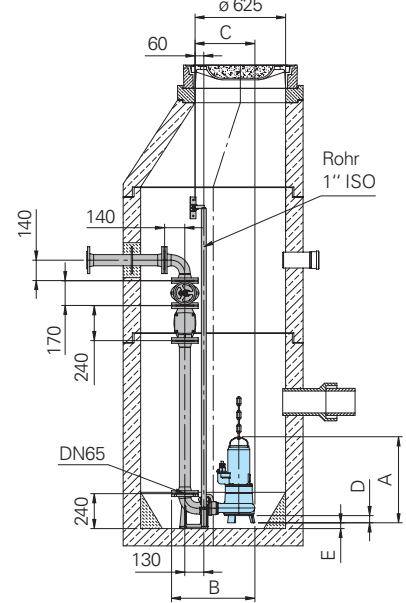

**Accessories**

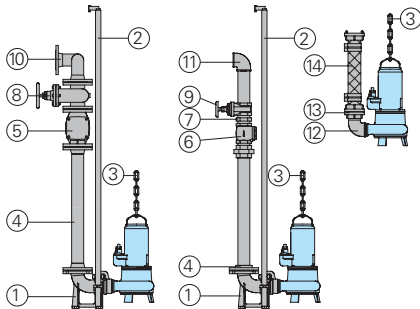

Part Description	Dimension	Part.-No.
① Auto-coupling system with Cast iron auto-coupling with flange		
Cast iron flanged pump coupling		
Cast iron upper slide rail bracket		
KK65/R2 1/2" DN65/R2 1/2"		8604015
○ Auto-coupling system complete or partial in stainless steel	all types	on request

Part Description	Dimension	Part.-No.
○ Screw-kits for installation of coupling system		on request
○ Inter. upper slide rail bracket	Ø 1" für KK65	7323714
② Guide rails, pair, per m steel galvanized	1" dia.	2190135
stainless steel	1" dia.	2190252
③ Lifting chain, proved capacity up 200 kg		
division 984 mm, 4x12 with eyelet		
2m long		2800371
special lengths		on request
Shackle stainless steel	for chain 5 mm Ø	2801390
④ Threaded flange	DN 65/ BSP 2 1/2" F	2215060
Flanged pipe	DN 65	On request
⑤ Cast iron swing check	DN 65	2212805
⑥ Cast iron swing check	BSP 2 1/2" F	2212513
⑦ Galvanized double nipple	BSP 2 1/2" M	2009025
⑧ Cast iron gate valve	DN 65	2216065
⑨ Bronze gate valve	BSP 2 1/2" F	22160255

Part Description	Dimension	Part.-No.
⑩ 90° flanged elbow	DN 65	2153301
Flanged Y-piece for twin-pump arrangement	3 x DN 65	2160002
	DN 65/65/80	2160004
⑪ 90° galvanized elbow	BSP 2 1/2" F	2113610
T-piece for twin-pump arrangement	BSP 2 1/2" F	2114308
⑫ 90° galvanized elbow	BSP 2 1/2" F/M	2111705
⑬ STORZ-fixed coupling	B-2 1/2" F	2010502
STORZ-hose coupling	B-75 mm dia.	2013502
⑭ Synthetic pressure hose with rubber lining	length 10 m	2611210
	length 15 m	2611215
and couplings,	length 20 m	2611220
B-75 mm dia.	length 30 m	2611230
Reinforced hose, per m	75 mm dia.	2632075
Hose bands	85/20	2308520
○ Control panel for single or twin pump stations for automatic operation		On request



HOMA Pumpenfabrik GmbH  
 P.O.Box 22 63, D-53814 Neunk.-Seelscheid  
 Tel. +49 (0) 22 47/702-0, Fax +49 (0) 22 47/702-44  
 e-mail: info@homa-pumpen.de  
 www.homapumps.com