

## Stainless steel submersible drainage pumps for chemically polluted drainage water. Spherical clearance 30 and 50 mm.

### CPM, CPV

#### Application

HOMA CP stainless steel submersible drainage pumps are suitable for pumping corrosive or chemically polluted drainage water, waste water or sewage. With their 30 and 50 mm spherical clearance they are especially able to pump liquids with larger suspended solids like fibres, textiles etc. They are used for various applications in public and private sector, trade and industry.

**DIN EN 12050-2:** Konformität und Bauart geprüft und überwacht von der LGA.

**Installation:** Transportable or permanent. Models with float switch control for automatic pump operation, depending on liquid level in the sump.

**Pumped liquid:** Drainage water or sewage containing soft solids and chemically polluted drainage water. pH-value 5-10. Max. liquid temperature: 40°C

**Operation:** motor submerged: permanent (S1) motor surfaced: short term (S2) or intermittent (S3), see technical data.

#### Design

Fully submersible, compact integrated motor-pump unit consisting of:

**Pump:** Single stage centrifugal pump with horizontal discharge.

**Impeller:** M = Open single channel impeller for liquids containing impurities and sludge with solid particles.

V = Vortex impeller for liquids containing a high level of impurities or fibrous matter and containing gas

**Motor:** Fully submersible, pressure tight electric motor. Insulation class F. Degree of protection IP 68. Thermal monitoring in the winding. cable: Model W: H07RN-F3G1 | Model D: H07RN-F4G1

**Shaft/Bearing:** Large diameter stainless steel rotor shaft, pre-lubricated bearings.

**Seals:** Combination of mechanical seals (silicon-carbide/silicon-carbide) and lip seal in separate oil chamber.

#### Performance

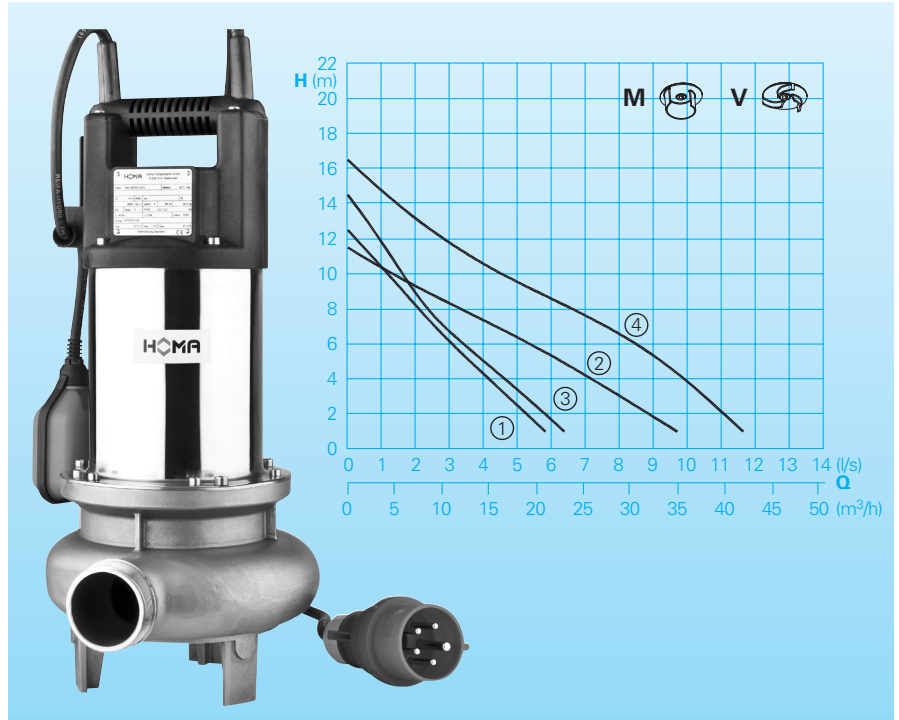

#### Technical Data

Curve No.	Pump type	Motor P <sub>1</sub> (kW)	Motor P <sub>2</sub> (kW)	Nominal current (A)	Discharge	Spherical clearance (mm)	Operation S2 (min)	S3* (%)	Weight (kg)
①	CPV 310 W(A)	1,0	0,7	4,4	G 1 ½ A	30	20	40	13
①	CPV 310 D(A)	1,0	0,7	2,0	G 1 ½ A	30	30	50	13
②	CPV 515 W(A)	1,5	1,2	6,5	G 2 A	50	20	40	16
②	CPV 515 D(A)	1,5	1,2	2,5	G 2 A	50	30	50	16
③	CPM 310 W(A)	1,0	0,7	4,4	G 1 ½ A	30	20	40	13
③	CPM 310 D(A)	1,0	0,7	2,0	G 1 ½ A	30	30	50	13
④	CPM 515 W(A)	1,5	1,2	6,5	G 2 A	50	20	40	16
④	CPM 515 D(A)	1,5	1,2	2,5	G 2 A	50	30	50	16

Speed: 2900 rpm

Model W: 230-240V/1Ph 50Hz

Model D: 400-415V/3Ph 50Hz

\* Example: 40% = 4 min operation + 6 min break (cycle time 10 min)

#### Materials

Pump housing, Impeller	Stainless Steel 1.4308
Motor housing	Stainless Steel 1.4301
Motor housing cover	Composite GFK 30
Rotor shaft	Edelstahl 1.4304
Mechan. connection parts	Stainless Steel
Elastomere	NBR
Mechanical seal	SiC / SiC

#### Equipment supplied

Pumps with base stand, 10 m of cable.

**Model W:** with plug type F.

**Model D:** with phase inverter.

**Model A:** with automatic level control HOMA-Nivomatik.

**Dimensions and Installations** (all dimensions in mm)

**Free standing pump with base stand**

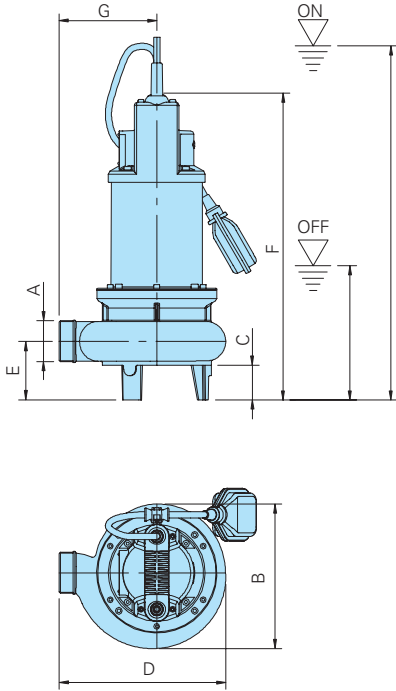

**Wet well installation with auto-coupling system  
KKC 50 / 2" - VA  
CPV(M) 310**

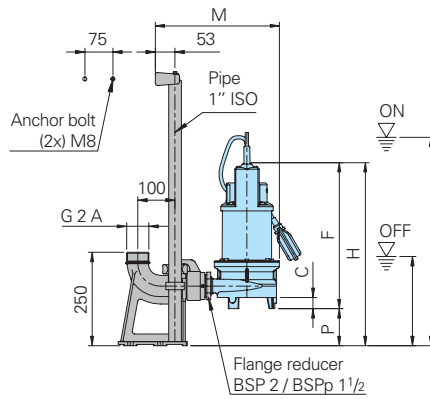

**Wet well installation with auto-coupling system  
KKC 50 / 2" - VA  
CPV(M) 515**

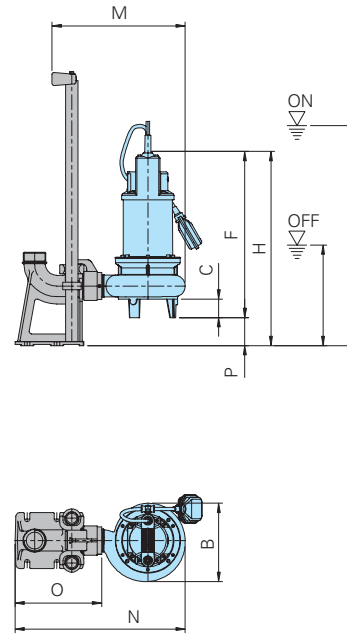

Pump type	A	B	C	D	E	F	G	H	M	N	O	P
CPV(M) 310	G 1 1/2 A	175	30	203	61	392	115	491	334	433	249	99
CPV(M) 515	G 2 A	210	50	242	85	446	142	521	357	457	233	75

Limit value float switch	ON	OFF
Base stand		
CPV(M) 310	410-460	140-190
CPV(M) 515	465-515	195-245
Coupling-system		
CPV(M) 310	509-559	239-289
CPV(M) 515	540-590	270-320

**Accessories**

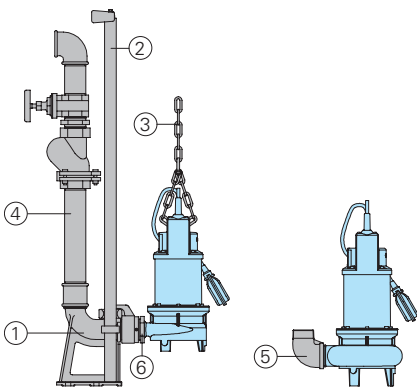

Description	Dimension	Part No.	Description	Dimension	Part No.
① Auto-coupling system stainless steel, with flange, flange pump coupling and upper slide rail bracket - KKC 50/R2"		8604011	Shackle, stainless steel	1,25 T-S width 25mm with splint, load capacity 1250 kg, prove	2801362
○ Screw-kits for installation of coupling system		on request	④ Stainless steel or plastic discharge pipe and fittings		on request
Inter. upper slide rail bracket	Ø 1" für KKC50	7323714	⑤ 90° elbow, stainless steel	BSP1 1/2/BSPp1 1/2 BSP2/BSPp2	2111824 2111507
② Guide rails, stainless steel	Ø 1"	2190252	⑥ Flange reducer, stainless steel (only for CPV(M) 310)	BSP2/BSPp1 1/2	2114318
③ Lifting chain, proved capacity up 200 kg division 984 mm, 4x12 with eyelet 2m long		2800371	○ Pump controls and control panels for permanent or transportable installation, level controllers and monitoring devices		see HOMA accessories
special lengths		on request			
Shackle, stainless steel	0,4 T-S width 21mm with splint, load capacity 400 kg, prove	2801360			



HOMA Pumpenfabrik GmbH  
P.O.Box 22 63, D-53814 Neunk.-Seelscheid  
Tel. +49 (0) 22 47/702-0, Fax +49 (0) 22 47/702-44  
e-mail: info@homa-pumpen.de  
www.homapumps.com